

Ameri Temp Ltd.

**Temporary Climate Control
and Power Equipment**

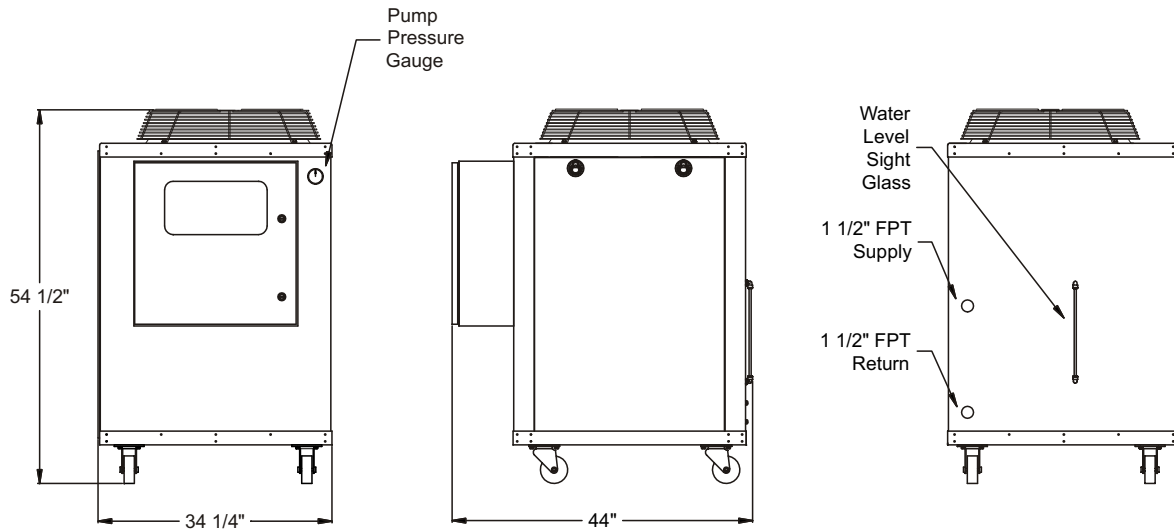

Model	Cooling Tons	Set Point Range °F	Refrigerant Type	Condenser Air Flow CFM	Unit MCA @ 460/3/60	Pump			Shipping Weight Lbs.
						HP	GPM	PSI	
SQ2A05	5.5	20 – 80	HCFC-22	4,400	18	1½	13	43	575

Cooling tons based on 12,000 BTU/Hr/ton with 50°F leaving coolant and 95°F ambient air

Mechanical Features

- Generously sized condenser for industrial environments (up to 115°F ambient temperatures)
- Encapsulated high and low refrigerant pressure safeties
- Top discharge fan and cleanable inlet air filter
- Nonferrous water circuit construction
- Insulated polyethylene reservoir with removable cover
- Energy efficient and reliable scroll compressor
- Stainless steel process pump with pressure gauge
- Electronic hot gas bypass for capacity control
- Fail safe flow switch interlocked with compressor
- Brazed plate evaporator provides higher heat transfer coefficients due to reduced fouling
- Y-strainer to protect evaporator from contamination
- Internal valved bypass line to protect pump and evaporator
- Refrigerant TXV, filter/drier, and sight glass
- Freezestat safety switch with solid state sensor
- Factory tested under full load conditions prior to shipment

Electrical Features

- NEMA 12 electrical enclosure with single point electrical connection
- Diagnostic lights (No Flow, High Refrigerant Pressure, Low Refrigerant Pressure, Freezestat, Under Set Point, Over Set Point, Pump On, Compressor On, Partial Load, High Water Temperature, Probe Fault)
- Control transformer to provide 115V/1/60 control voltage
- Dual LED digital displays of actual and set point temperatures
- Switches with indicating lights (Power, Start, Stop, Alarm Reset)
- PID control algorithm
- Anti-cycle timer to prevent short-cycling of compressor

Warranty

- 5 year controller warranty, \$175 lifetime exchange policy
- 18 months parts, 12 months labor warranty, F.O.B. Arlington Heights, Illinois

Unit MCA @ 460/3/60

Pump	SQ2A05
1½ HP	18
3 HP	19
3 HP, 2-stage	19